

June 18th – 22nd, 2023

Bryon Curnutt

ATR Lead Fuels Engineer

ATR



IRRADIATION TESTING FACILITY OF CHOICE

A Fast Reactor Irradiation Experiment Design in the ATR

Introduction to ATR

- Water-cooled and moderated thermal test reactor completed in 1967. ATR remains one of the newest and most capable test reactors in the world
- Utilizes plate type, aluminum clad HEU UAlx fuels. ATR provides thermal fluxes ranging from $5E13$ n/cm^2*s to $5E14$ n/cm^2*s , depending on irradiation position.
 - Fast flux (> 1 MeV) ranges from $3E12$ n/cm^2*s to $2E14$ n/cm^2*s
 - Dose rates of 5 DPA / year in stainless steels are routinely reached
- Serpentine arrangement of 40 fuel elements surround 9 flux traps. Core configuration offers an additional 76 irradiation test positions in its beryllium reflector and aluminum neck shim housing. With an active fuel length of 48 inches, ATR provides substantial real estate for irradiation testing.
- A rich history of capsule, loop (i.e. in-pile tube) and instrumented lead out irradiation tests
- Collocated with INL's world class suite of properties testing and characterization equipment in shielded hot cells.



ATR Core



Hot Fuel Exam Facility

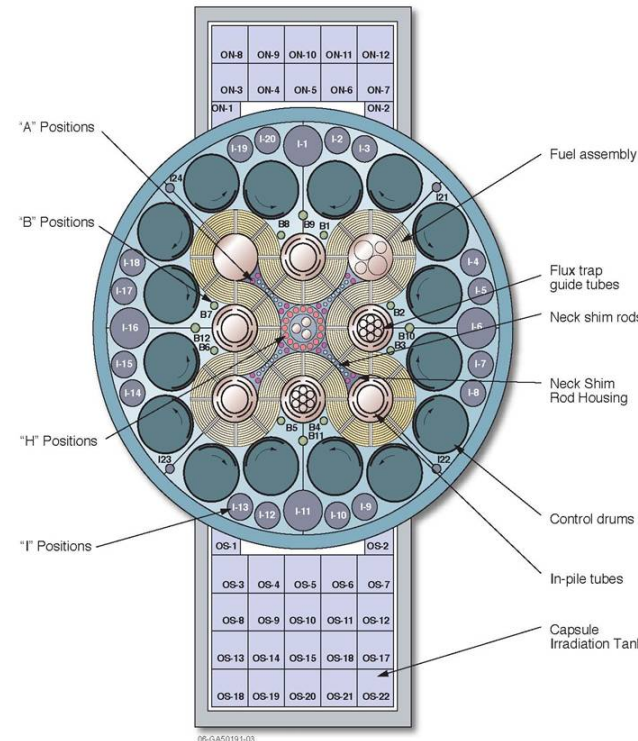

Table 2. Approximate peak flux values for various ATR capsule positions for a reactor power of 110 MW_{th} (22 MW_{th} in each lobe).

Position	Diameter (cm/in) ^a	Thermal Flux (n/cm ² -s) ^b	Fast Flux (E>1 MeV) (n/cm ² -s)	Typical Gamma Heating W/g (SS) ^c
Northwest and Northeast Flux Traps	13.3/5.250	4.4×10^{14}	2.2×10^{14}	
Other Flux Traps	7.62/3.000 ^d	4.4×10^{14}	9.7×10^{13}	
A-Positions (A-1 - A-8)	1.59	1.9×10^{14}	1.7×10^{14}	8.8
(A-9 - A-16)	1.59/0.625	2.0×10^{14}	2.3×10^{14}	
B-Positions (B-1 - B-8)	2.22/0.875	2.5×10^{14}	8.1×10^{13}	6.4
(B-9 - B-12)	3.81/1.500	1.1×10^{14}	1.6×10^{13}	5.5
H-Positions (14)	1.59/0.625	1.9×10^{14}	1.7×10^{14}	8.4
I-Positions				
Large (4)	12.7/5.000	1.7×10^{13}	1.3×10^{12}	0.66
Medium (16)	8.26/3.500	3.4×10^{13}	1.3×10^{12}	
Small (4)	3.81/1.500	8.4×10^{13}	3.2×10^{12}	

Fast Neutron Irradiation Testing in ATR

- The advanced nuclear fuels mission is interested in a fast spectrum environment to represent fast spectrum advanced reactors
 - Fast reactors are not available in the west – the proposed Versatile Test Reactor (VTR) is currently unfunded with a doubtful future
 - ATR test positions can be, and have been designed to harden the incident neutron spectrum. Tests can be designed to boost the incident flux
 - This presentation focuses on a promising and feasible test idea to boost fast flux
- Why fast neutrons?
 - Achieve representative atom lattice damage in proposed fast reactor materials
 - Minimize spurious effects from thermal neutron capture transmutation damage
 - Create representative self shielding, fission driven thermal / burnup gradients in fissionable materials
- Shared needs in both the fast reactor and fusion communities

Current ATR Fast Neutron Testing Capabilities

- The Advanced Fuel Campaign (AFC) design has been the workhorse and has provided years of successful irradiation testing
 - Utilizes prototypic Sodium Fast Reactor (SFR) diameter - short specimen lengths ~ 3.8 cm
 - Clad fissionable test specimen encapsulated in stainless steel pressure and safety boundary. Helium and/or Argon gas gap between cladding and capsule used to force clad and fuel centerline temperature.
 - Cadmium lined baskets (hold capsules in irradiation positions) abate thermal neutrons to harden incident flux. Cadmium baskets have provided radial power profiles in fissionable specimens 'representative' of SFRs (INL/EXT-17-41677).
 - Provide heat generation rates (HGRs) prototypic to SFRs.
 - 3 at % HM burnup per year
 - 3 – 5 dpa per year in cladding

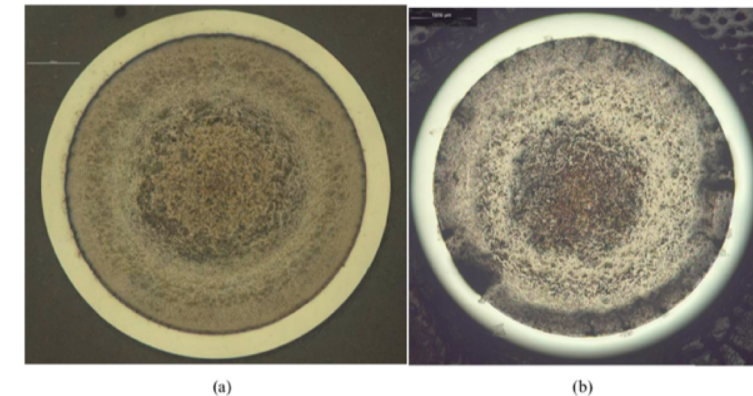
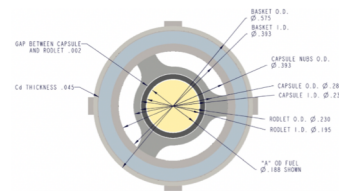
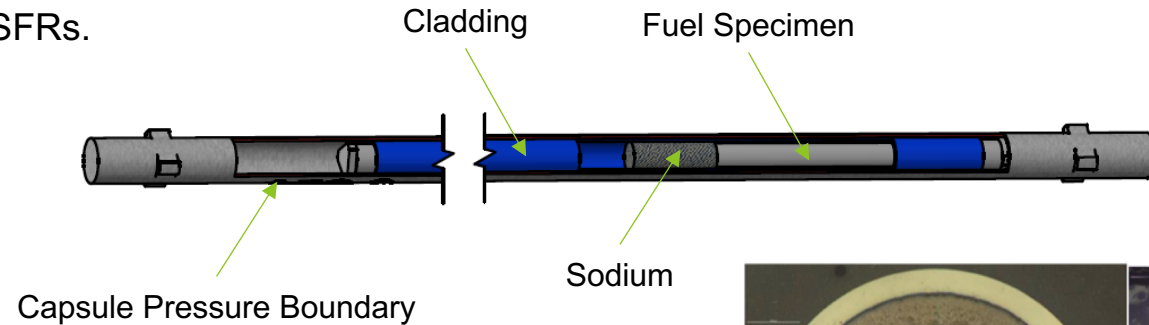
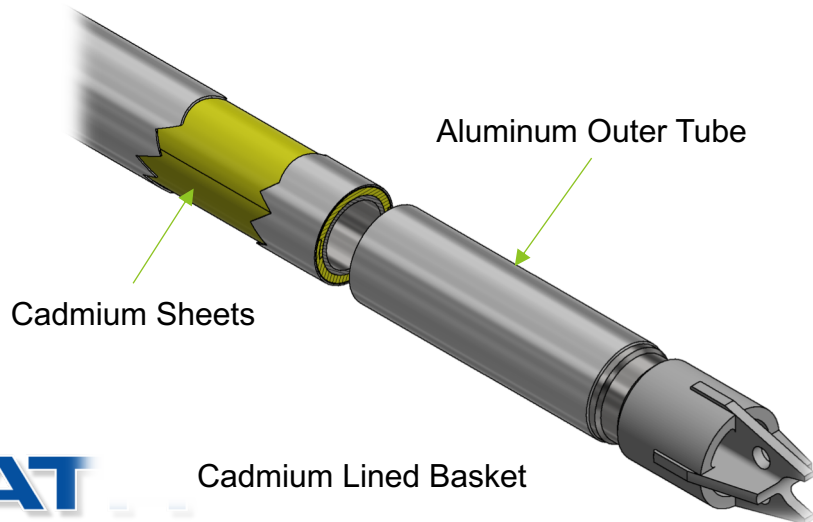
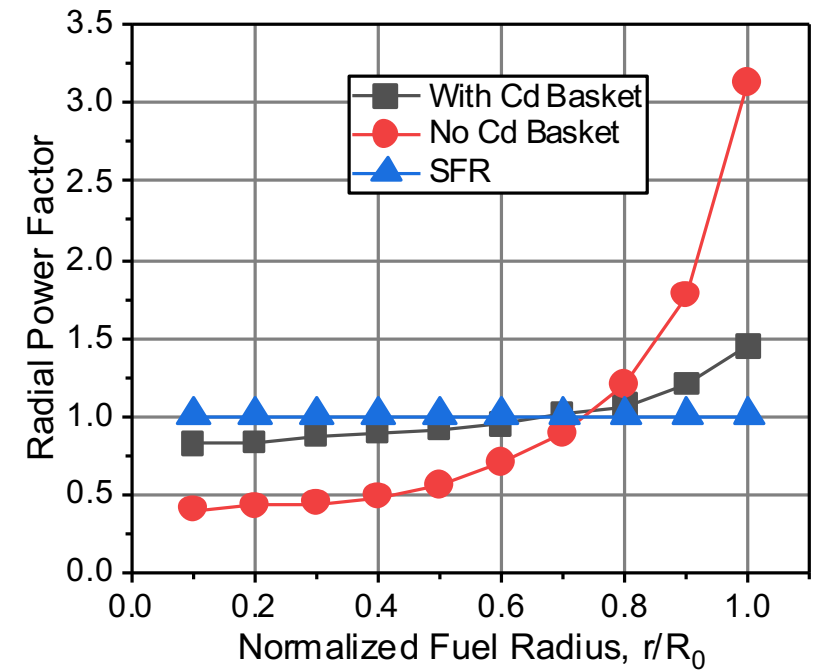
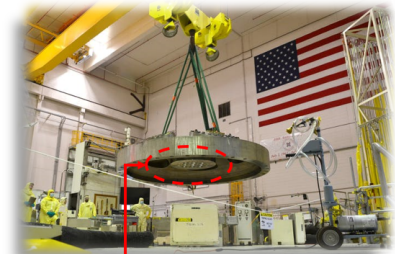
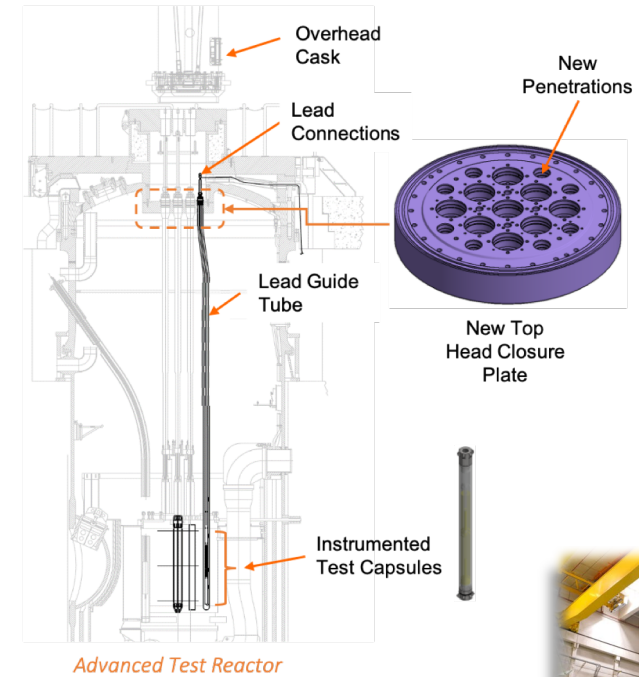

Figure 69. Metallography of Pu-12Am-40Zr irradiated to approximately 20% burnup in: a) Phénix fast reactor (FUTURIX-FTA DOE2), and b) cadmium-filtered position in ATR (AFC-1D R4).

Future Capabilities

- Instrumented tests
 - New top head closure plate installed in 2022 facilitates instrumented capsules penetrations
 - First utilization in 2023; in-situ thermal conductivity probe, fast reactor fuel pins in cadmium lined basket
- Boosted Energy Advanced Spectrum Test (BEAST)
 - Booster fuel (BR2 driver element) coupled with Cd filter in flux trap
 - Full-length fast reactor pins w/ prototypic HGRs
 - Large and small flux traps under assessment



ATR's vessel head being lifted into place after CIC with new top head closure plate installed

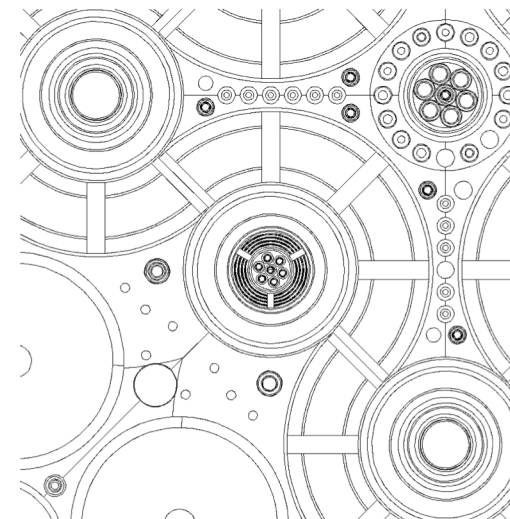
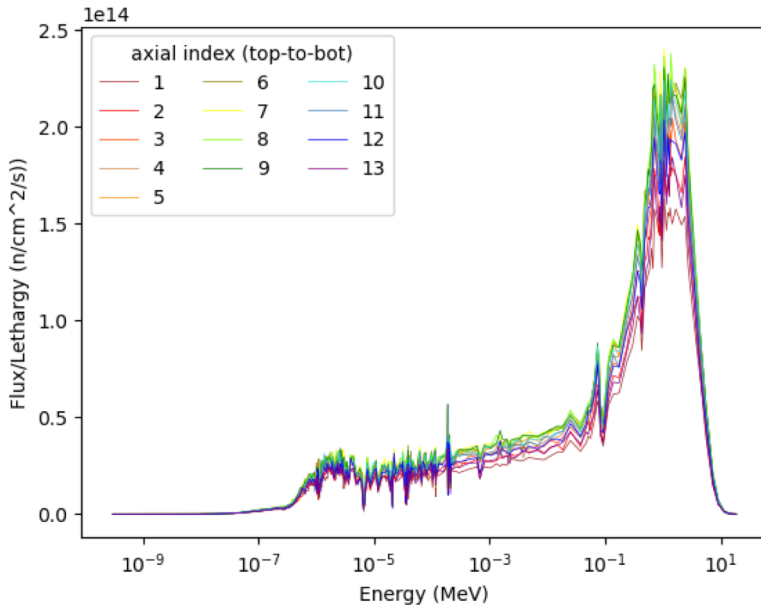

BEAST in NE Flux Trap

- Type SVG BR2 Fuel Element (5 Ring – 15 plate) modeled in NE flux trap
 - 366 grams of ^{235}U in Type SVG element
 - Each BR2 fuel plate discretized in 5° radial and 1 inch axial segments
 - Modeled and depleted as unique fuel cells
 - Enough real estate for basket assembly and 7 pin hexagonal array of SFR pins
 - 150% increase in fast flux $> 100\text{ keV}$
 - Cadmium and Eu_2O_3 evaluated as thermal neutron filters

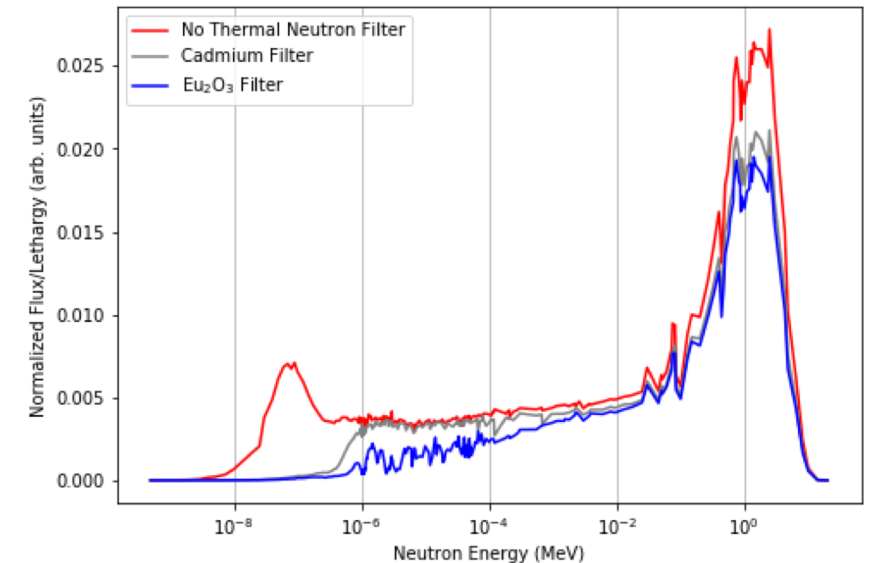
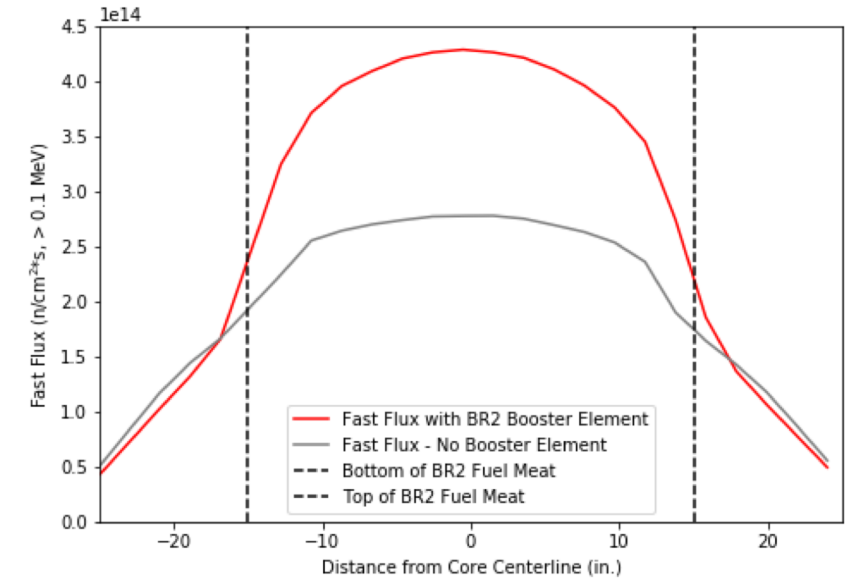
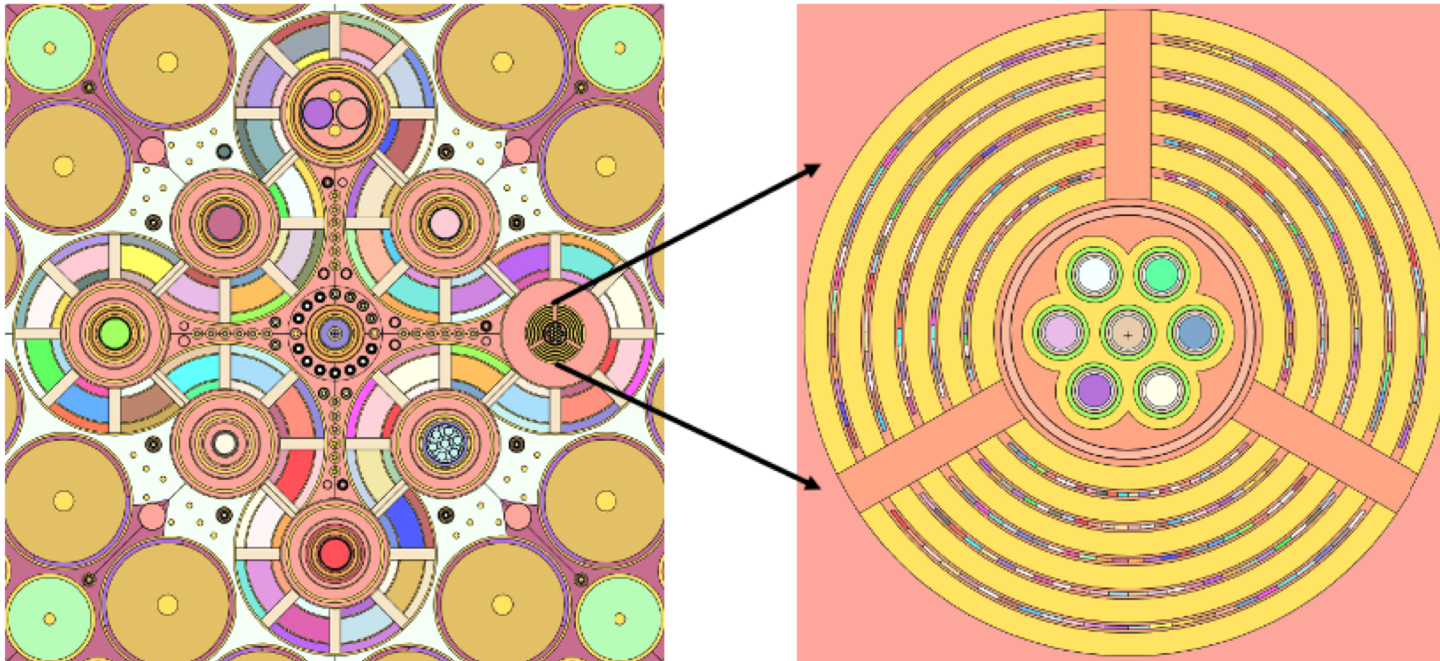

Analytical Methodology

- 3-D full core Monte Carlo N-Particle (MCNP) model of ATR
- 21-zone ATR driver fuel element model
 - Each ATR fuel element modeled in 3-radial and 7-axial homogenized regions
 - Historical parametric studies demonstrated the 21-zone model provides accurate solutions with a significant decrease in compute time relative to 19 plate model
- ATR Cycle 158B fuel element loading representative
 - Unique irradiation experiment in cycle 158B
 - Driver fuel element for an international research reactor with similar ^{235}U loading and fuel to moderator ratio as a BR2 driver element irradiated in 158B
 - BR2 in the NE flux trap would require very similar fuel element loading and operational requirements
- MCNP run with KCODE option (eigenvalue search)
- MCNP to ORIGEN2 python script (MOPY) used to loosely couple calculations
 - Numerous MCNP calculations to converge on neck and OSCC positions to yield k_{eff} of 1
 - Flux and reaction rate tallies made of driver fuel element, BR2 and BEAST experiment regions; ORIGEN2 one group cross-sections calculated for each region then passed to ORIGEN2 for depletion
 - ORIGEN2 calculated isotopics of each region then passed to subsequent MCNP input time step file.

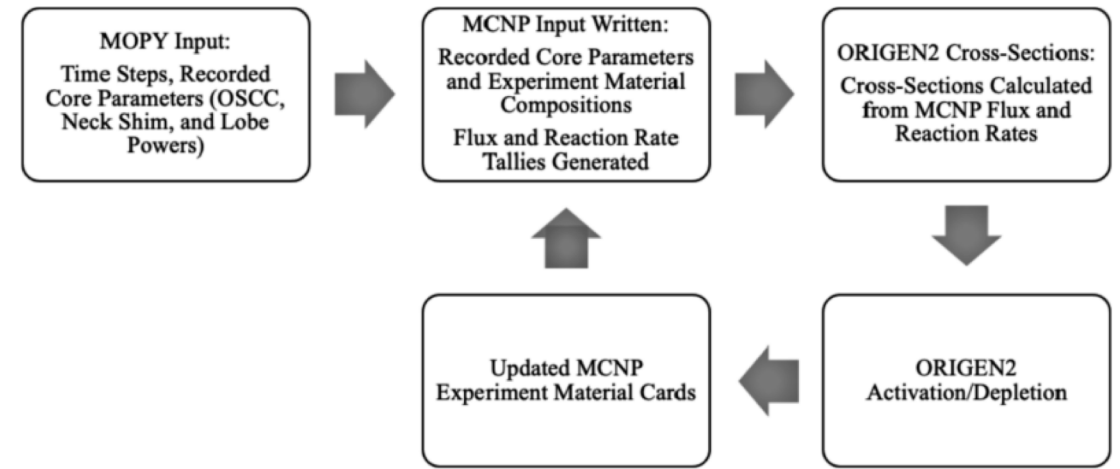

$$RR = C \int \phi(E) R_m(E) dE$$

where

C = Multiplicative constant (set to 1 for cross section calculations)

$\phi(E)$ = Energy dependent Flux

R_m = energy dependent reaction rate of interest

The standard MCNP flux tally calculates the quantity:

$$Flux = \int \phi(E) dE$$

Depletion Results

- BR2 total element power ranged from 0.9 to 1.0 MW
 - Roughly $\frac{1}{2}$ of ATR element power operating in a 19 MW lobe
 - Moderate BR2 plate powers
 - BR2 plate peak HGR ranged from 220 W/cm² to 260 W/cm²
- Peak fission density of 6.9E20 fissions/cm³ after the 51 day cycle
- 69 wt % ²³⁵U U10Zr SFR fuel pins reached a burnup of 0.9 at% HM after 51 days at power
 - LHGRs of ~ 350 W/cm

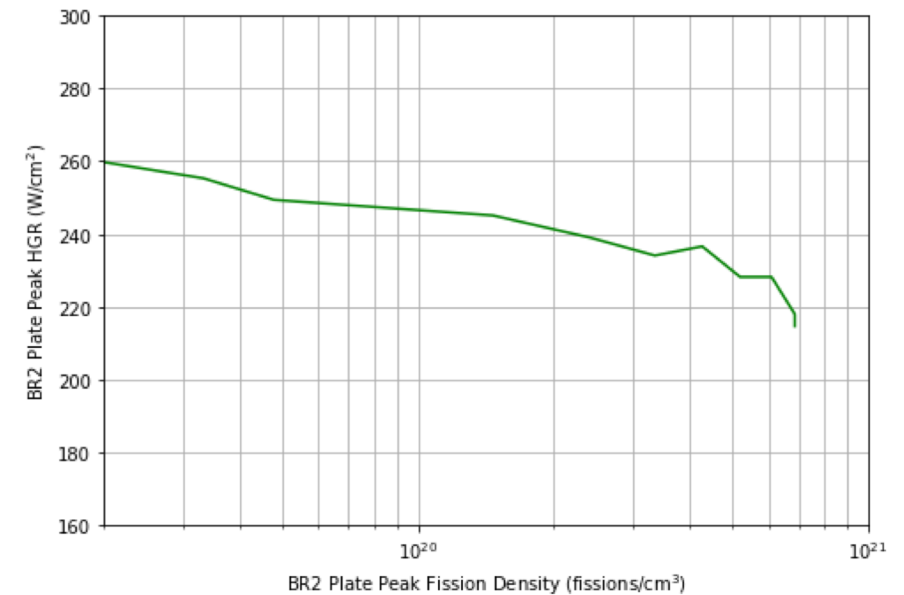
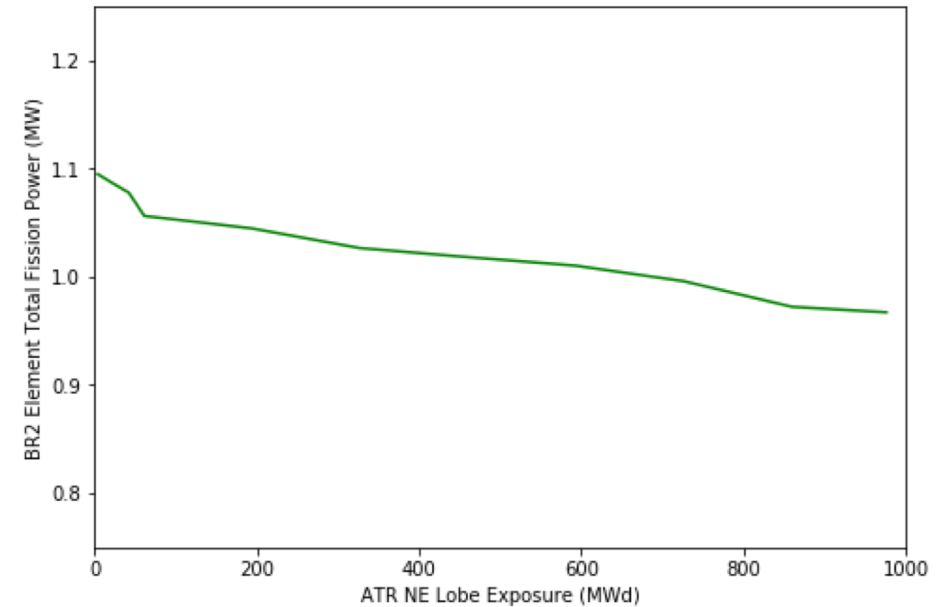

SFR Experiment in BEAST Scoping

- Numerous experiment design iterations simulated
 - Cadmium and Eu_2O_3 lined basket assemblies
 - No aluminum reducer (region outside BR2 element and inside NE flux trap)
 - Beryllium reducer
 - Aluminum and molybdenum flower assembly
 - Water and sodium coolant inside flower
- Al reducer, Cd lined basket assembly, Al flower and water cooled provide the best balance of experiment performance and feasibility relative to fabricability and nuclear safety requirements
- Calculated radial power profiles similar to historical AFC-OA experiments and recent Fission Accelerated Steady state Test (FAST)
 - Not prototypic of SFRs, but representative enough for SFR testing (INL/EXT-17-41677)

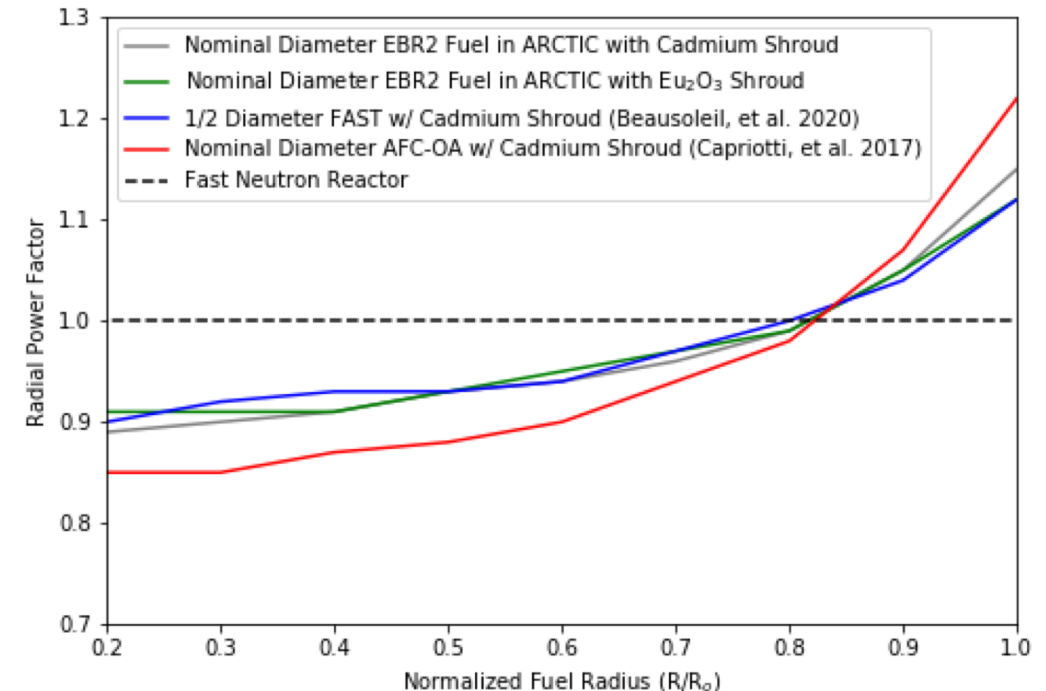
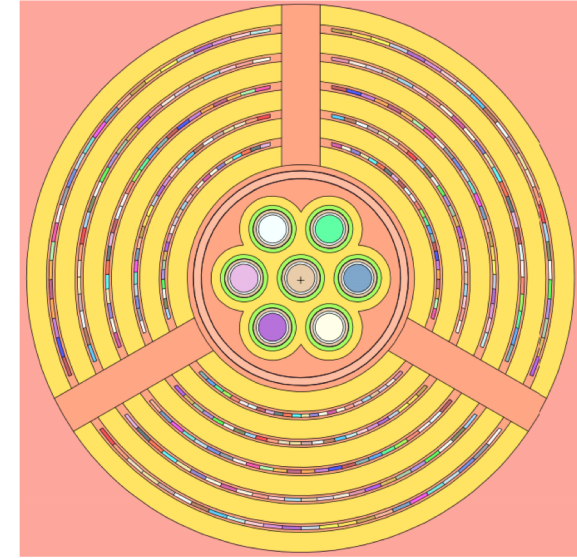

Conclusions

- The AFC program is developing BEAST: An instrumentation-capable fast spectrum neutron irradiation test bed in ATR
 - Ample irradiation real estate for fuels and materials for both fast-fission and fusion communities (LiD converter scoping has been performed with optimistic results)
 - Consideration in small and large flux traps
- BEAST deployable in 2-3 years with adequate resources
- AFC considering starting immediately with experiments in traditional positions and hardware to be shuffled into BEAST when it comes available