



**TR** **TRTR**  
National Organization of Test,  
Research and Training Reactors

**IGORR**

International Group on  
Research Reactors

**TRTR & IGORR**  
**RESEARCH REACTOR CONFERENCE**  
June 18-22, 2023  
The Hotel  
at the  
**University of Maryland**  
<https://www.trtr.org/>  
<https://www.igorr.com/>



UNLOCK THE POWER OF SIMULATION

# Simulation Assisted Engineering SAE Applied to New Builds





- Introduction to WSC
- What is SAE?
- SAE Phases with Sample Projects and Benefits
- Summary
- Questions





- ❑ Founded in 1995 with over 250 simulators delivered successfully
- ❑ Employees: ~ 85; Multidisciplinary team of nuclear, mechanical, electrical, chemical engineers, physicists and computer scientists, 30% with advanced degrees.
- ❑ Research Oriented – over 20% of gross profit goes into R&D
- ❑ Headquarters in Frederick, Maryland, USA
- ❑ Main Business - Power Plant Simulation
  - Nuclear Power Plant Simulators 40%
  - Conventional Power Plant Simulators 30%
  - Simulation Assisted Engineering 20%
  - Navy and Marine Simulation 5%
  - Process and Pipelines 5%
- ❑ ISO 9001:2015 & ISO 27001:2013 Certified

More than 700 Man Years Simulation Experience

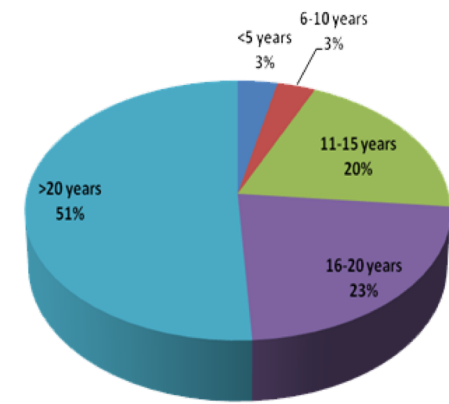

More than 730 Man Years Nuclear Experience

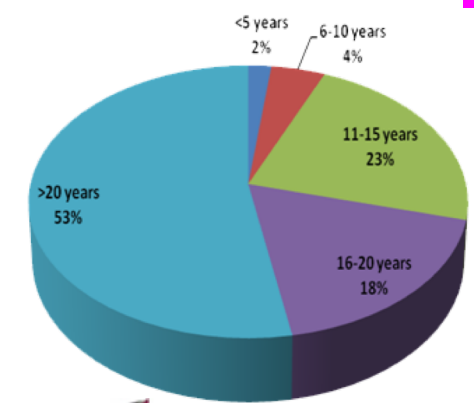



## High Fidelity Simulators for use in the:

### ❑ Development of Replica Training Simulators

- Nuclear, Coal, Combined Cycle Gas Plants, ...
- Part-Task and Full-Scope Simulators
- Classroom Simulators
- Web based simulators

### ❑ Simulation Assisted Engineering (SAE)

- System Analysis and Design
- Human Factors
- Logic and Control Testing & V&V
- Plant Optimization
- Plant Test and Operating procedures – e.g. commissioning procedures



# Classroom & Web based

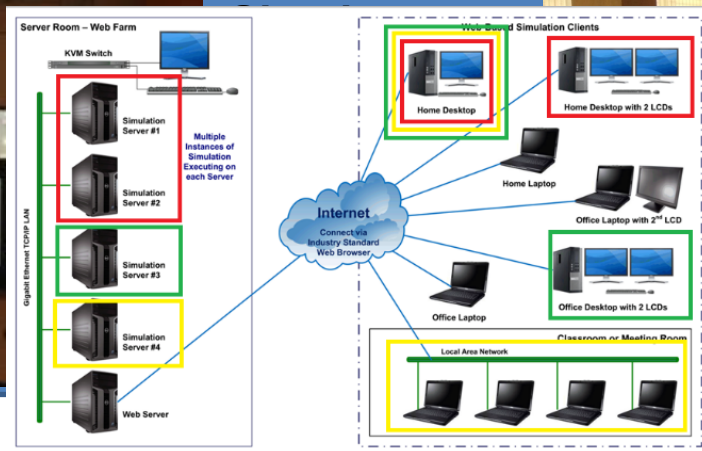

Touch  
Screen  
Virtual  
Panels





## 3KEYMASTER™ Simulation Platform and Modeling Tools - Flagship for this Suite

- Graphical Engineering Station for Simulation Development and Control / Instructor Station
- 2-Phase Flow network Tool
- Electrical Network Tool
- Logic & Control and Relay Tools
- Component Tool and Library



3KEYRELAP5-RT™ – Adaptation of INEEL’s RELAP-3D®, including NESTLE, to run in real-time with visualization, provides best-estimate engineering grade modeling for Thermal-hydraulics and Neutron Kinetics



3KEYSAA™ – Severe Accident Analysis Models MELCOR / MAAP



3KEYTOUCH™ – Alternative Training Delivery Platform / Control Room Glasstop Simulators



3KEYSTUDENT™ – Web and Classroom based Simulator Lesson delivery



3KEYITS™ – Intelligent Tutoring System



- WSC has the experience of embedding complex models into the simulator
- RELAP5 / TRACG / MARS Thermal-Hydraulic Codes
- NESTLE / S3R Neutronic Models
- MELCOR / MAAP Severe accident models.

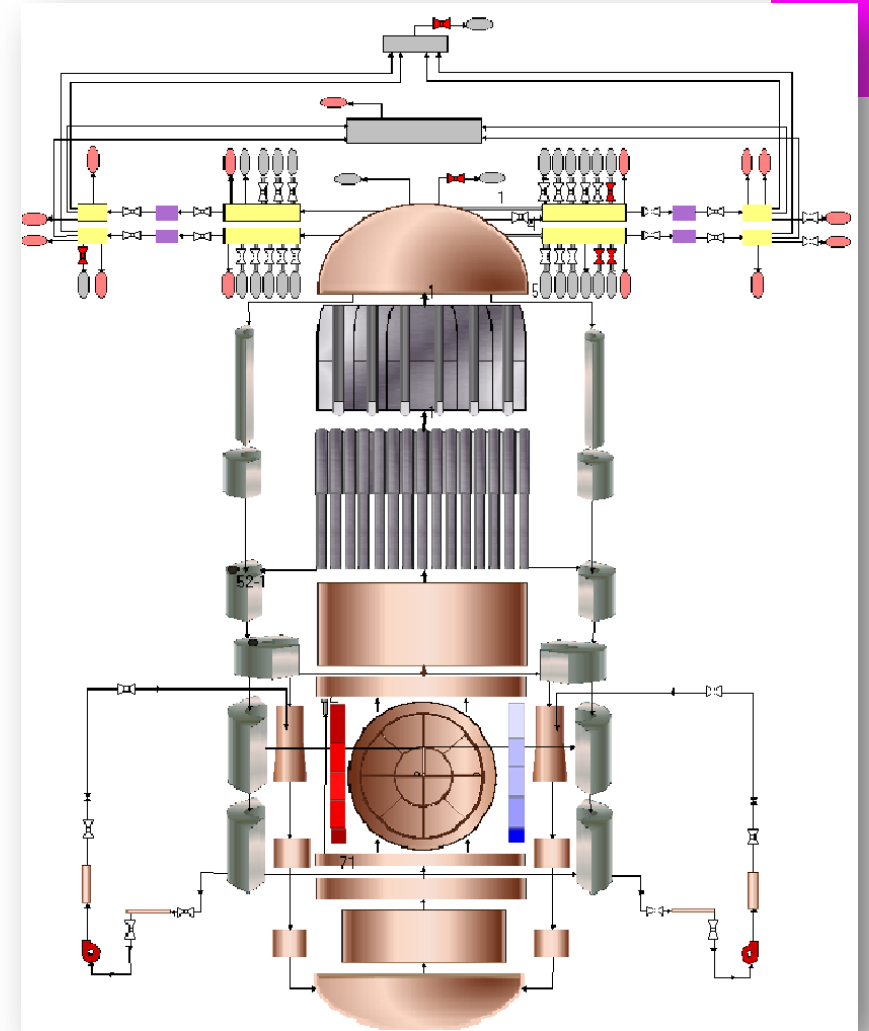



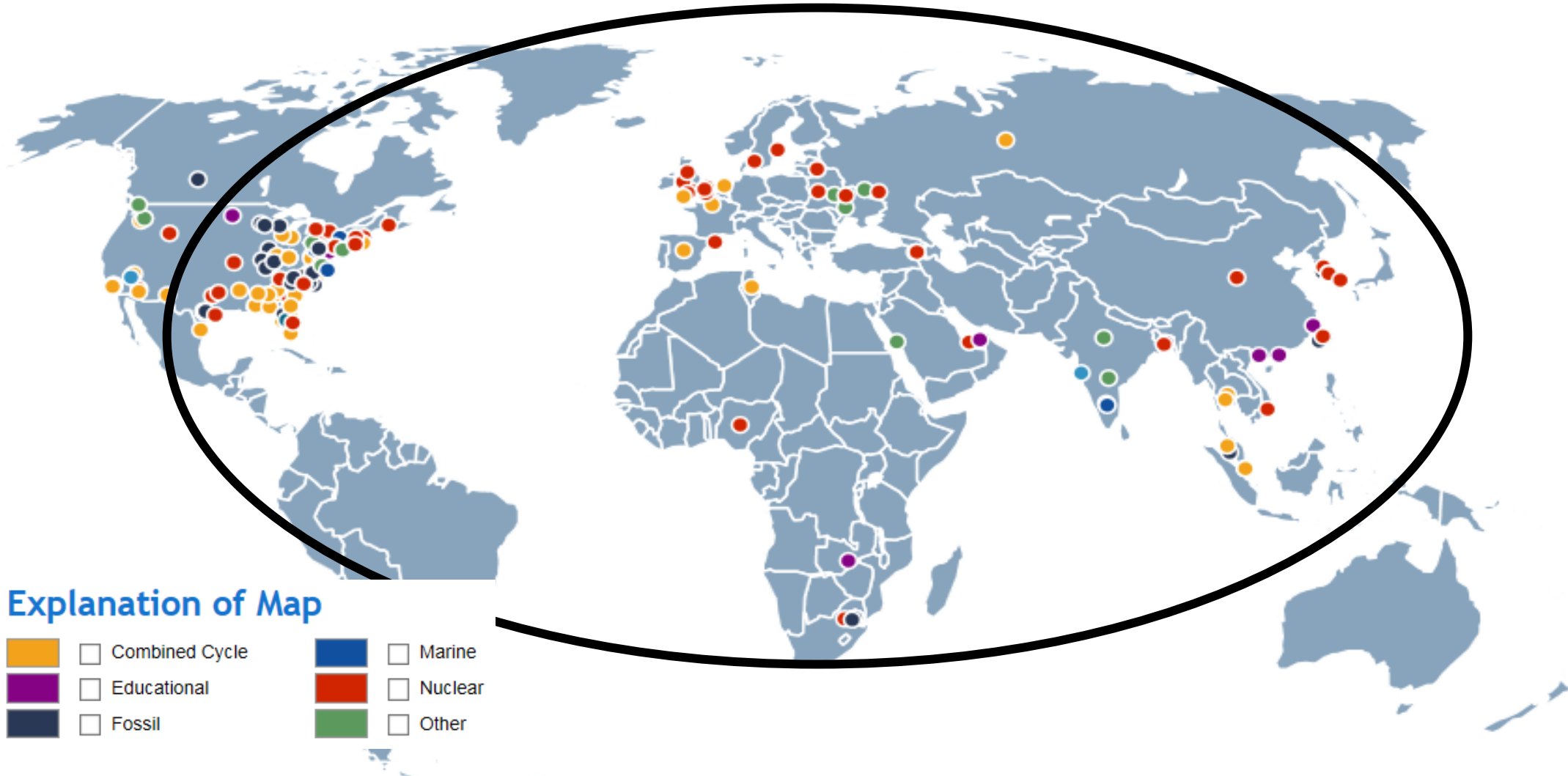

## Explanation of Map

- |                                                                                                                                           |                                                                                                                                 |
|-------------------------------------------------------------------------------------------------------------------------------------------|---------------------------------------------------------------------------------------------------------------------------------|
| <span style="display: inline-block; width: 15px; height: 15px; background-color: orange; border: 1px solid black;"></span> Combined Cycle | <span style="display: inline-block; width: 15px; height: 15px; background-color: blue; border: 1px solid black;"></span> Marine |
| <span style="display: inline-block; width: 15px; height: 15px; background-color: purple; border: 1px solid black;"></span> Educational    | <span style="display: inline-block; width: 15px; height: 15px; background-color: red; border: 1px solid black;"></span> Nuclear |
| <span style="display: inline-block; width: 15px; height: 15px; background-color: darkblue; border: 1px solid black;"></span> Fossil       | <span style="display: inline-block; width: 15px; height: 15px; background-color: green; border: 1px solid black;"></span> Other |



WSC provides simulation software solutions to power and process clients and education institutions worldwide, and teams with various strategic partners, in efforts to deliver innovative, collaborative solutions

### Power Companies

### Universities & Research Institutes

### Partners



## Recent nuclear new builds and next generation reactors selecting WSC technology:

- Korea Hydro Nuclear Power, Barakah Plants, all Korean APR 1400 PWR units,
- China Guangdong Nuclear Power Company, Ningde, Yang Jiang & Fangchengang CPR 1000, CNRSC Generic CPR 1000 with Severe Accident Modelling
- Emirates Nuclear Energy Corporation (ENEC) in UAE for Barakah NPP GPWR Classroom Simulator and Full Scope Simulators
- Toshiba ABWR, South Texas
- Taiwan Power Company TPC, Lungmen ABWR
- Chinergy China HTR PBMR
- KAERI Maritime and SMART SMR
- GE-Hitachi, ESBWR/BWRX300 SMR SAE
- TerraPower Traveling Wave Reactor & Sodium SMR
- Holtec SMR 160
- BWXT MMR Pele Project





*SAE provides an effective test bed through all phases of project execution commencing at conceptual design through the building and commissioning of a complex asset such as a nuclear power plant.*



# Companies that have used SAE with WSC



Tran  
Simu

Hi  
S  
f  
Tr  
Er

Engineering  
Simulators

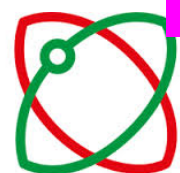



**Scoping & Pre-Sale Support**  
**Process Flow Diagrams**  
**Systems Engineering**  
**Human Factors Engineering**  
**Safety Analysis**

**Conceptual Design & Licensing**

**Piping & Instrumentation Diagrams**  
**Thermal-hydraulic Performance**  
**Logic & Control Design**  
**Electrical Design**  
**Equipment Specification**

**Design & Build**

**Integrated Plant Design Verification**  
**I&C, DCS Testing & Tuning**  
**Commissioning Procedure Verification**  
**System Pre-Testing**  
**Fault Diagnosis**

**Testing & Commissioning**





- Developing process flow sheets and nominal operating parameters for equipment
- Specifying system boundaries and integration parameters at key operating conditions
- Conducting human-factors engineering studies and developing HMI design
- Conducting preliminary failures and safety analysis studies for single or complex failures

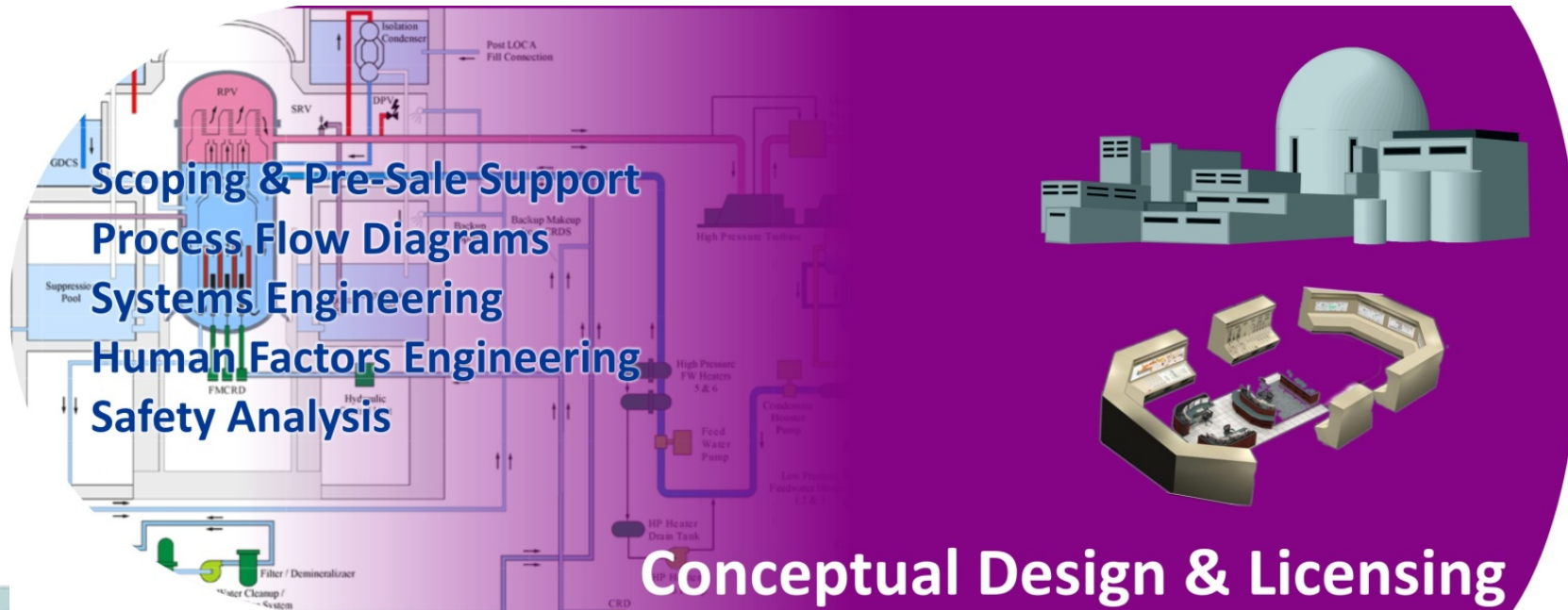



KEPRI\_HFE\_VTS\_02\_1

## Development of the integrated HFE V&V System for the Advanced Digitalized MCR MMIS

R&D Leading & Participating

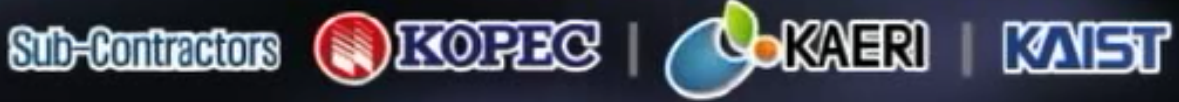

### Why HFE are so important?

One of the most important key factors → HFE



**Chernobyl disaster in Russia**  
 began as a result of a series of human errors

### Why HFE are so important?

One of the most important key factors → HFE



**TMI accident in United States**  
 Caused by mis-diagnoses and incorrect situation awareness of operators





*The APR-1400 (Advanced Power Reactor 1400 MW electricity) is an advanced pressurized water nuclear reactor designed by the Korea Electric Power Corporation (KEPCO). The Generation III reactor was developed from the earlier OPR-1000 design and also incorporates features from the US Combustion Engineering (C-E) System 80+ design.*



Site	Unit	Status	Construction Start	Construction Complete	Operation
<a href="#"><u>Shin-Kori</u></a> S. Korea	3	Operational	Oct 2008	Late 2015	2016
	4	Operational	Aug 2009	Late 2018	2019
	5	under construction	Sept 2016	–	Mar 2021
	6	under construction	Sept 2017	–	Mar 2022
<a href="#"><u>Shin-Hanul</u></a> S. Korea	1	under construction	July 2012	–	2022
	2	under construction	June 2013	–	2023
<a href="#"><u>Barakah</u></a> Abu Dhabi UAE	1	Operational	July 2012	2018	2020
	2	Operational	May 2013	2020	2022
	3	Operational	Sept 2014	2021	2023
	4	under construction	Sept 2015	2022	2024



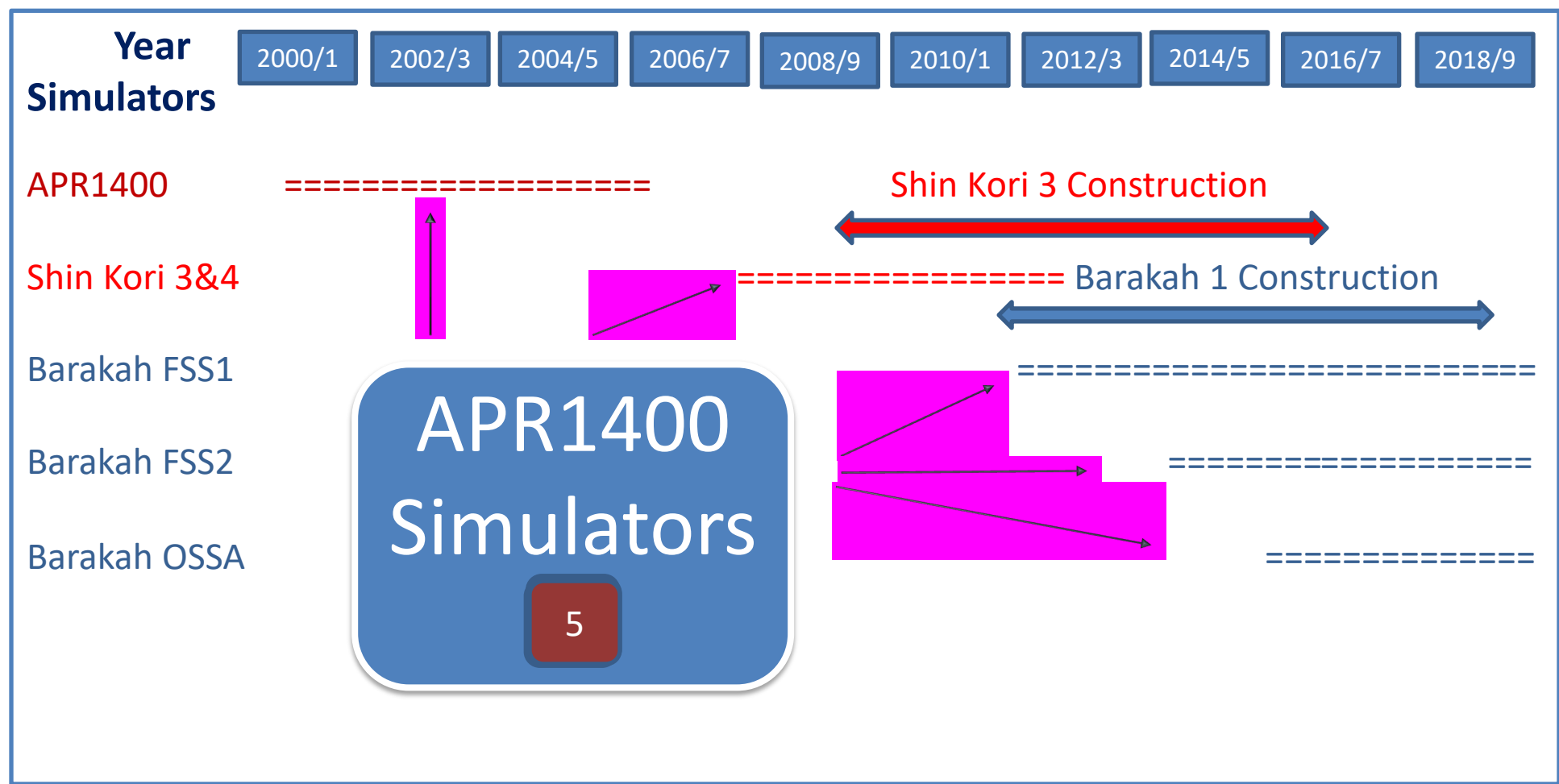

- Full Replica Simulator for the Purpose
  - Control Room Ergonomics
  - Plant Control Room and Control Room Operator Behavior
  - Test Design Basis
  - Certification of Design
  - Support Tool for Licensing Agency







Cameras and Operator Action sensing equipment. Eye movement, heartbeat, head and hand movement





مؤسسة الإمارات للطاقة النووية  
Emirates Nuclear Energy Corporation

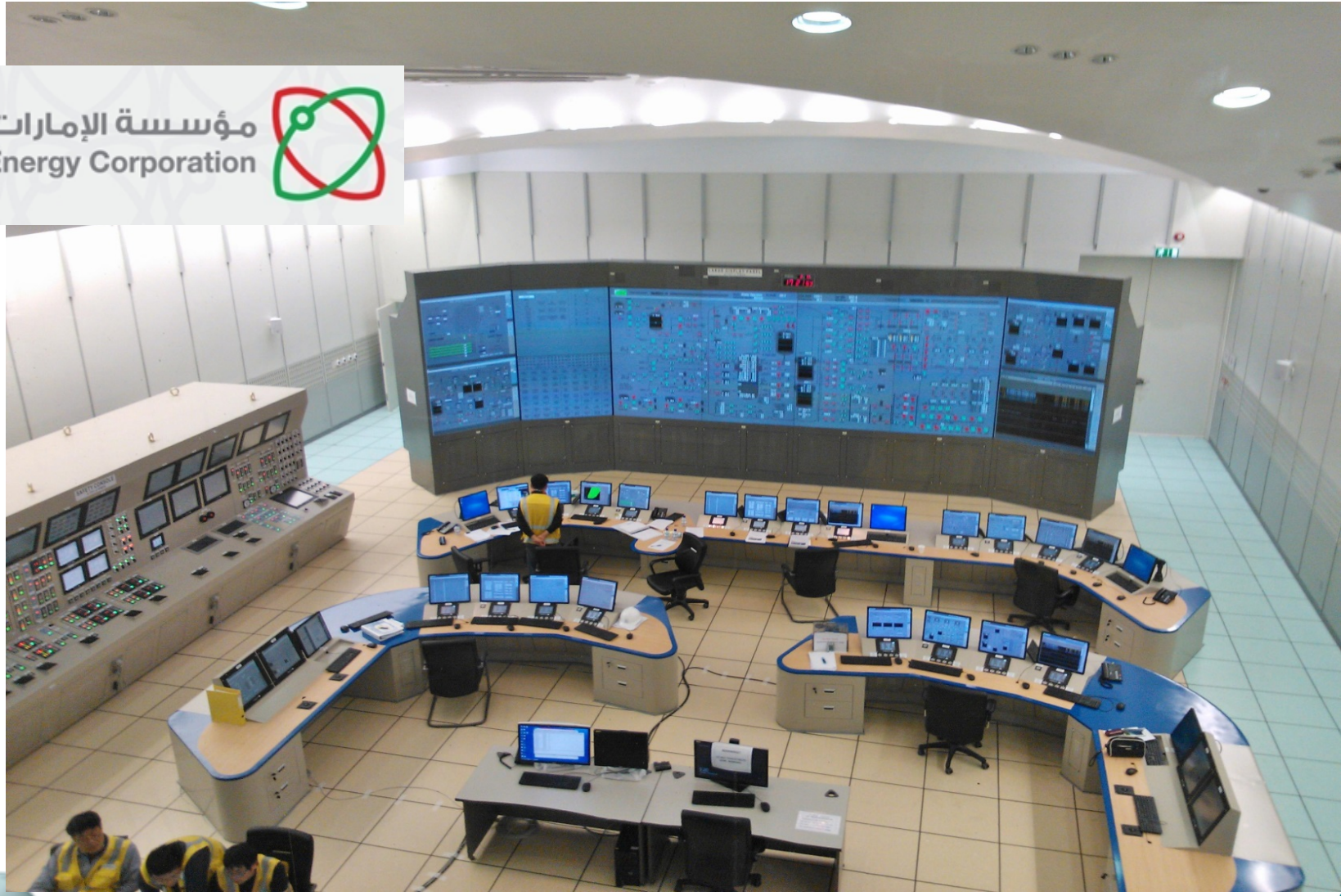

- Needed a Human Factors tool to evaluate incremental changes over several years
- Operating crews can validate the proposed placement of controls before the design is finalized

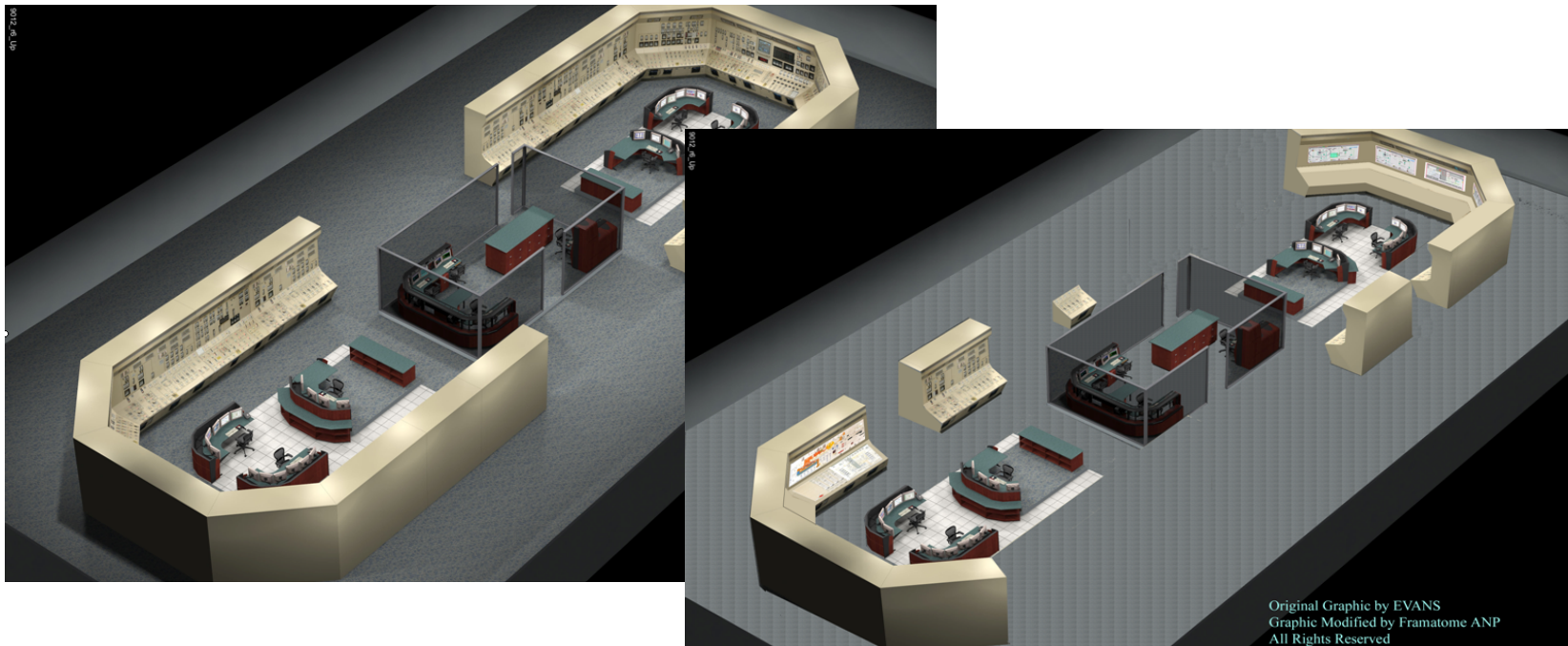



- Replicate Hard Panel Control Room with Touch Screen Replica Control Room
- Used for integration of New DCS Systems and modernization of the plant
- HFE Evaluations and Training on Updated Systems

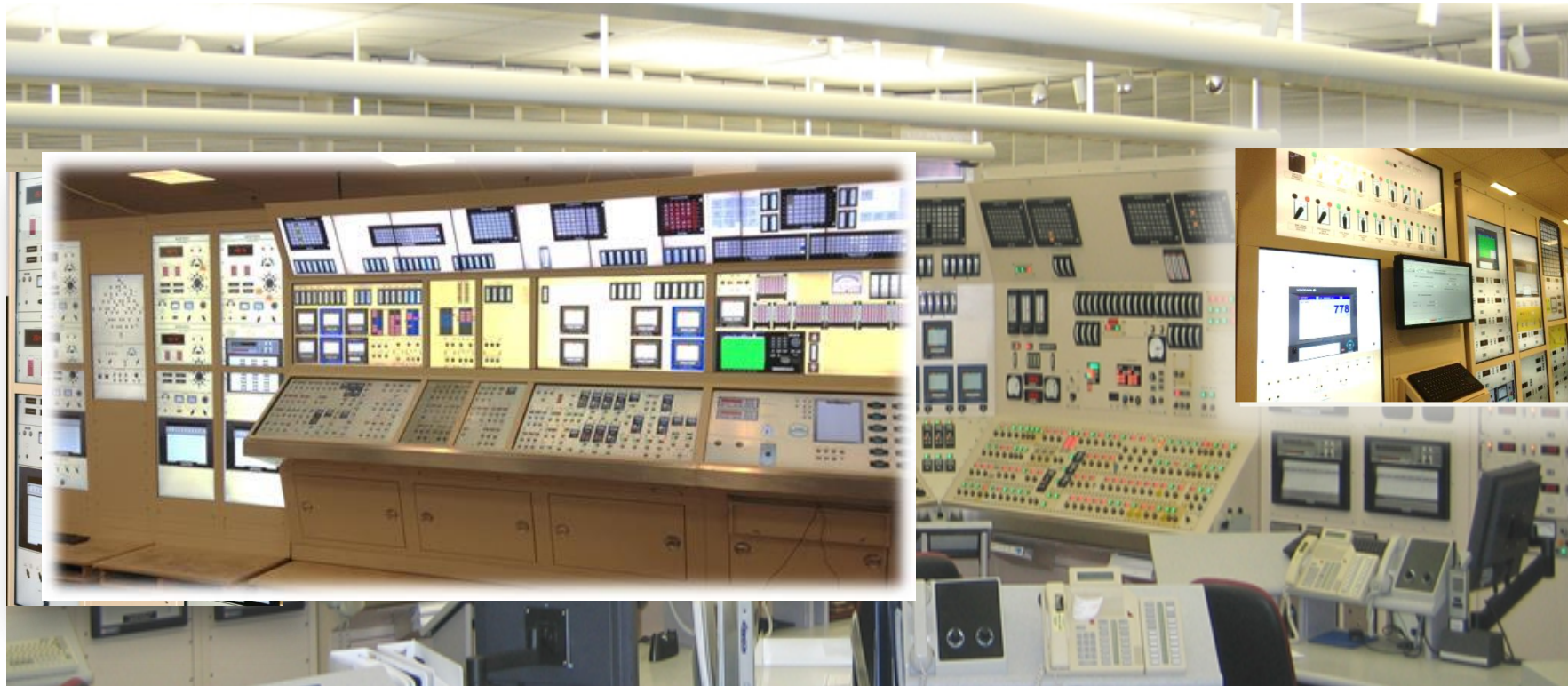



## Actual Control Room Panel



## Touch Screens Control Room Panel





Scoping & Pre-Sale Support  
 Process Flow Diagrams  
 Systems Engineering  
 Human Factors Engineering  
 Safety Analysis

**Conceptual Design & Licensing**

Piping & Instrumentation Diagrams  
 Thermal-hydraulic Performance  
 Logic & Control Design  
 Electrical Design  
 Equipment Specification

**Design & Build**

Integrated Plant Design Verification  
 I&C DCS Testing & Tuning  
 Commissioning Procedure Verification  
 System Pre-Testing  
 Fault Diagnosis

**Testing & Commissioning**





- Developing systems engineering artifacts — P&IDs, Logic & Control and Electrical Diagrams
- Developing equipment sizing and capacity specifications
- Engineered safety features and redundancy design

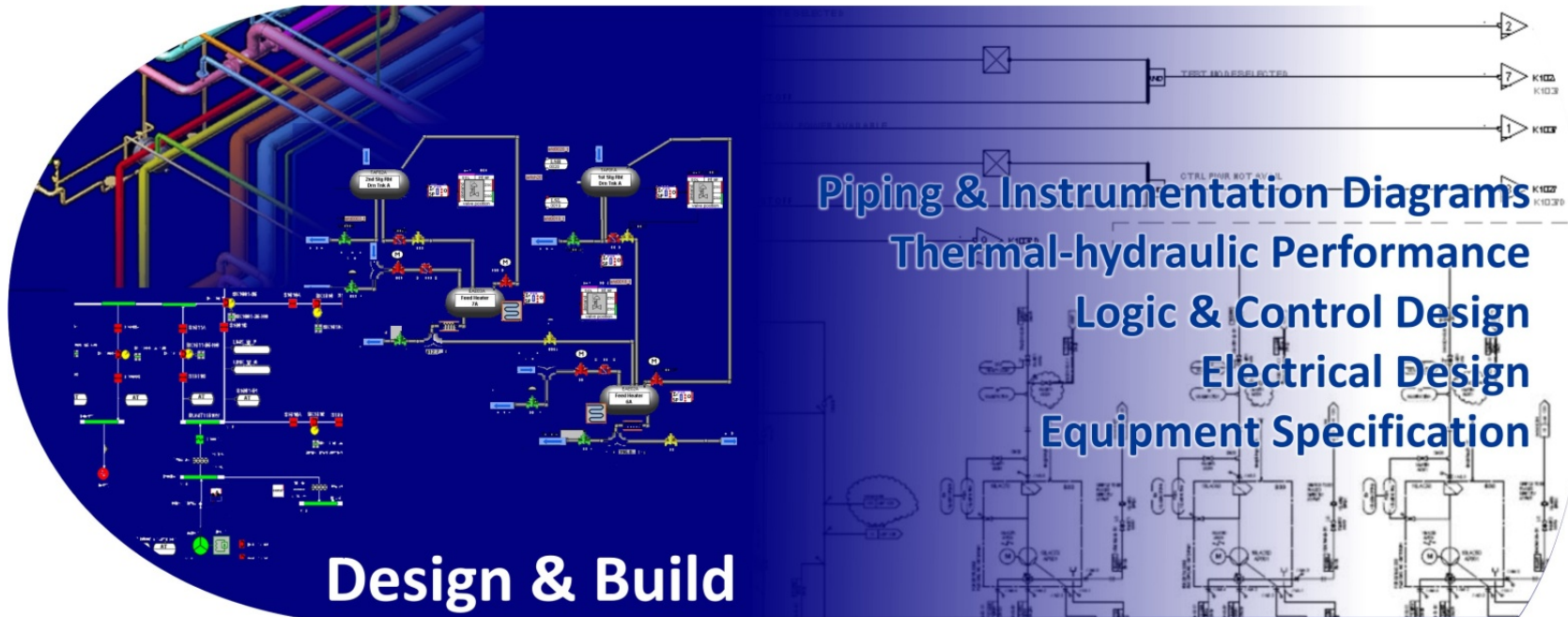



- Piping and Instrumentation Diagrams
- Isometrics and 3D models
- Electrical Diagrams
- Equipment Data
- Functional Logic and Control
- Initial HMI design



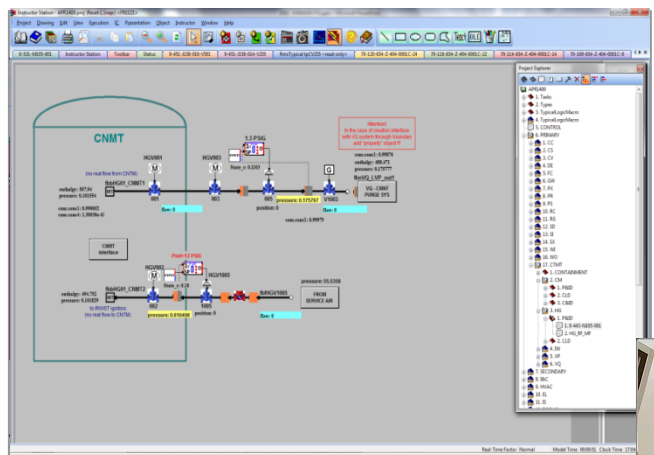

← Piping and Instrumentation

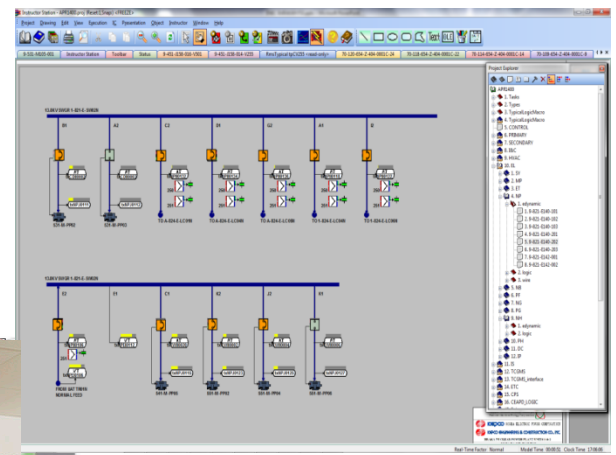

Electrical →

Control →



← HMI

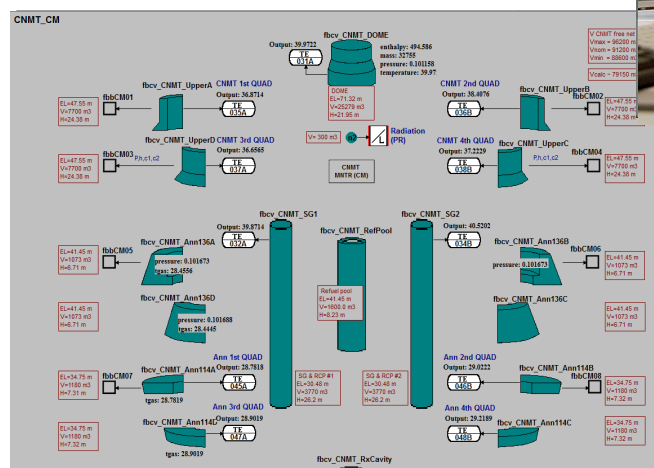

← Isometrics

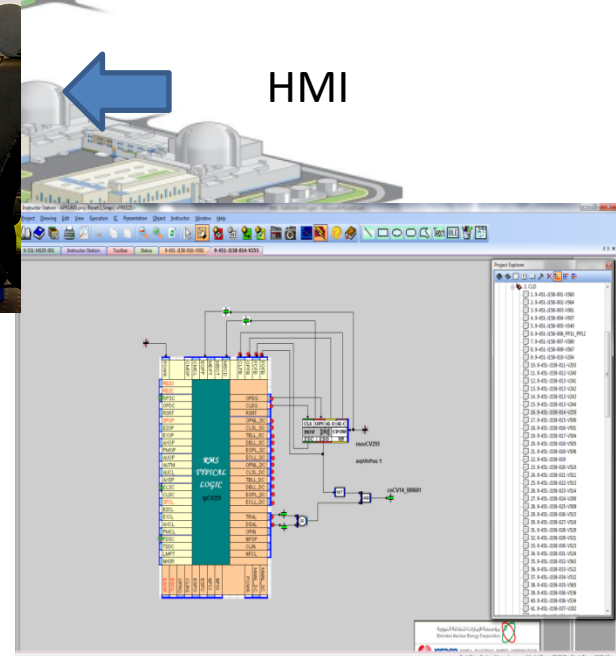

Instrumentation →

- Verification of Piping and Instrumentation
- Equipment Sizing
- System to system interfaces “the glue”
- Verification of Isometric Data
- Instrumentation effectiveness and location
- Evaluation of electrical systems loading and distribution
- Regulatory Compliance
- Plant Data Handover and configuration





**Scoping & Pre-Sale Support**  
**Process Flow Diagrams**  
**Systems Engineering**  
**Human Factors Engineering**  
**Safety Analysis**

**Conceptual Design & Licensing**

**Piping & Instrumentation Diagrams**  
**Thermal-hydraulic Performance**  
**Logic & Control Design**  
**Electrical Design**  
**Equipment Specification**

**Design & Build**

**Integrated Plant Design Verification**  
**I&C, DCS Testing & Tuning**  
**Commissioning Procedure Verification**  
**System Pre-Testing**  
**Fault Diagnosis**

**Testing & Commissioning**





- Virtual commissioning and verification of the entire integrated plant
- Performing DCS systems functional and sensitivity tests, and tuning
- Verifying test and operating procedures
- Verifying response to failures and faults
- Identifying and diagnosing problems, and exploring solutions to these

**Integrated Plant Design Verification**  
**I&C, DCS Testing & Tuning**  
**Commissioning Procedure Verification**  
**System Pre-Testing**  
**Fault Diagnosis**

**Testing & Commissioning**





## Approach:

- Integrate simulation into design process
- Identify defects and performance gaps
- Iterate to optimize & validate

## Virtual Plant



## Physical Models

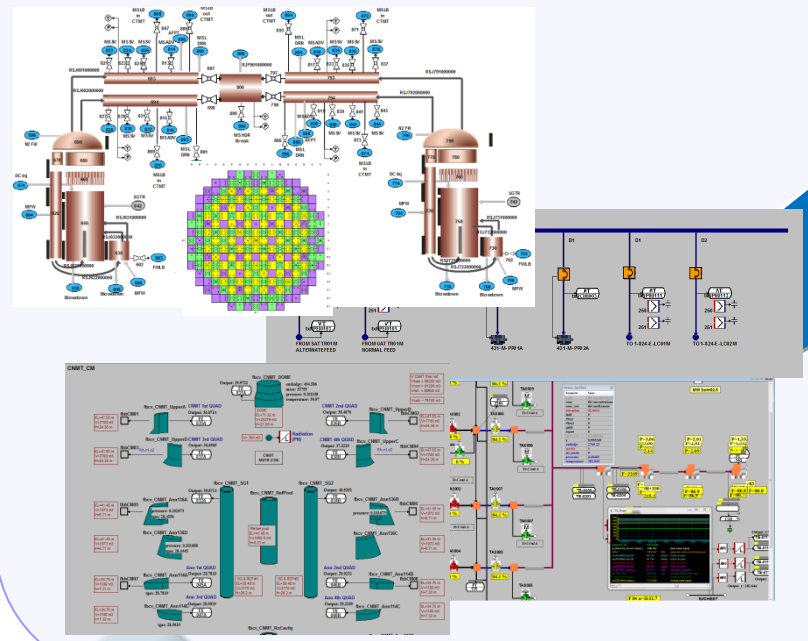

## Control Models

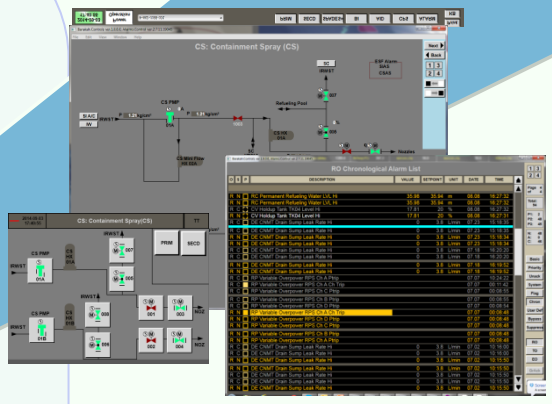

## Soft Controls or Hard Panels

## Benefits:

- Simplify design process
- Minimize overall defects and reduce rework for plant



## PLANT DATA

## VIRTUAL PLANT

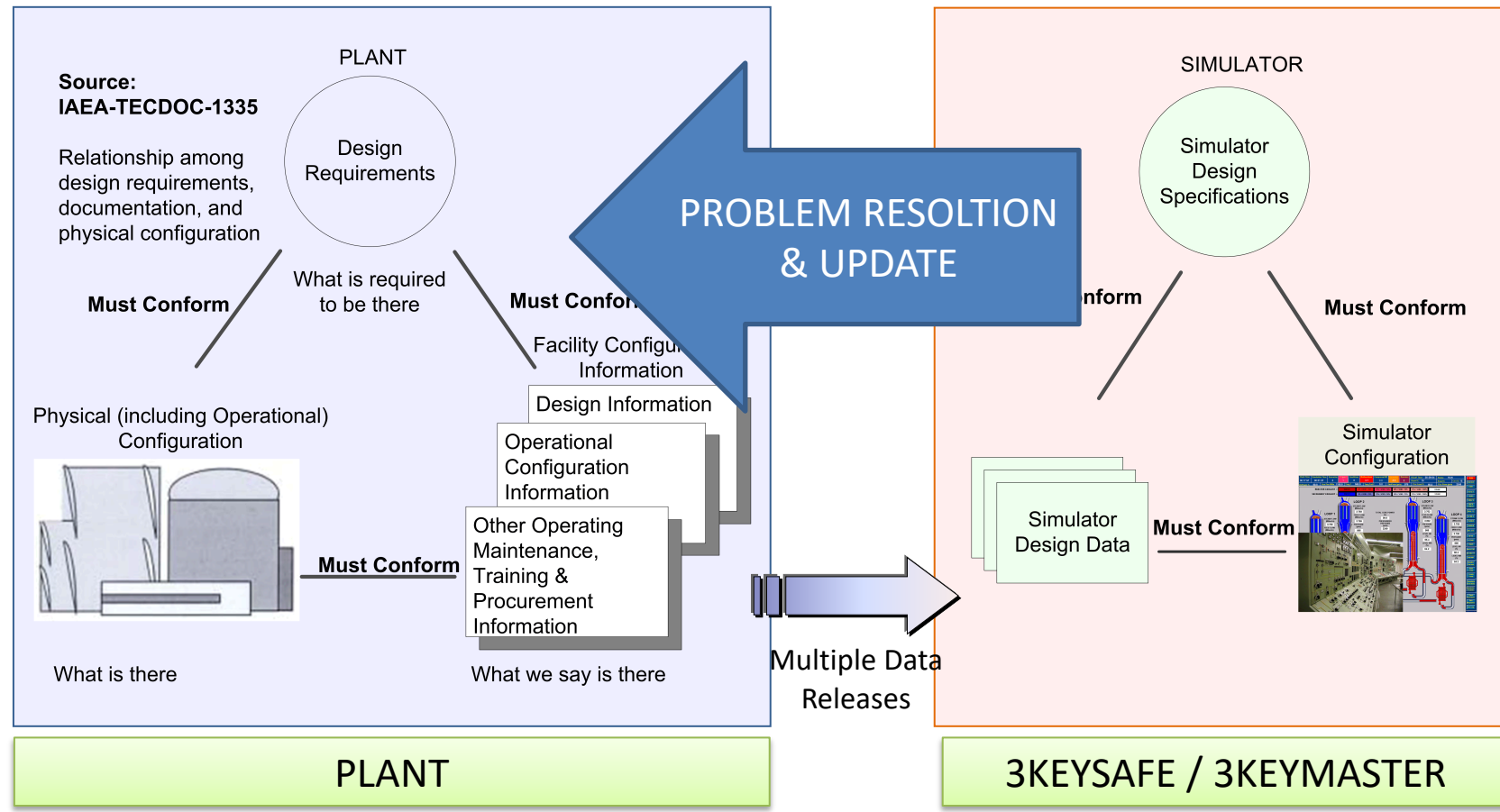



## DCS 1

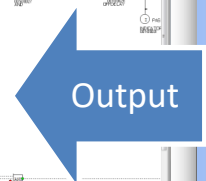
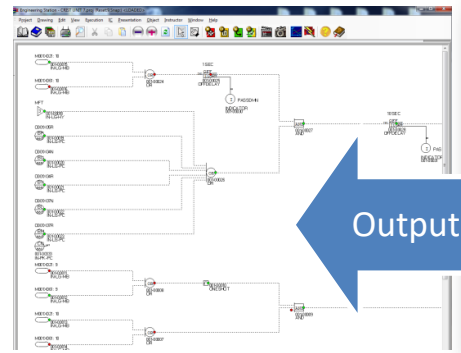

## DCS 2

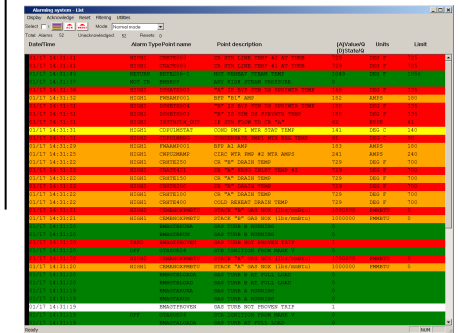
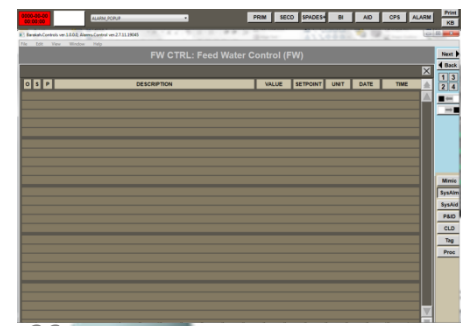
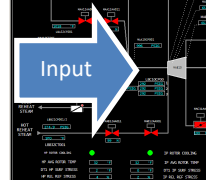
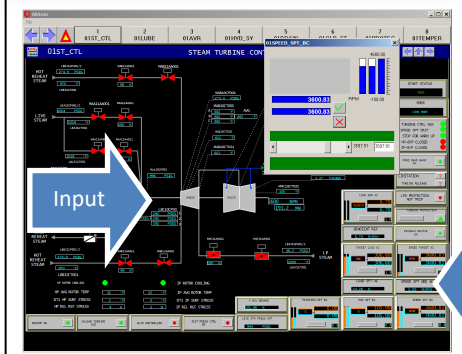
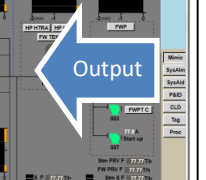
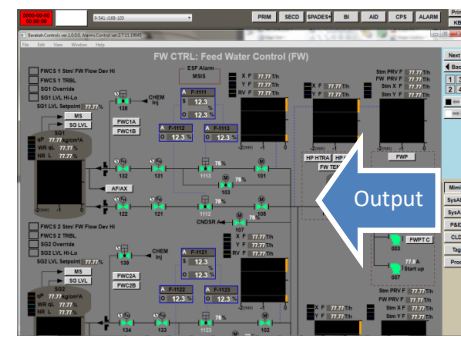

## DCS/PLC Interface

## DCS 3

## Process Models

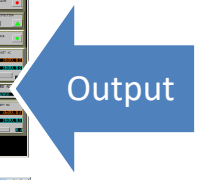
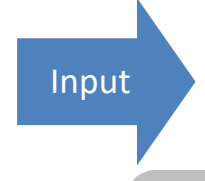
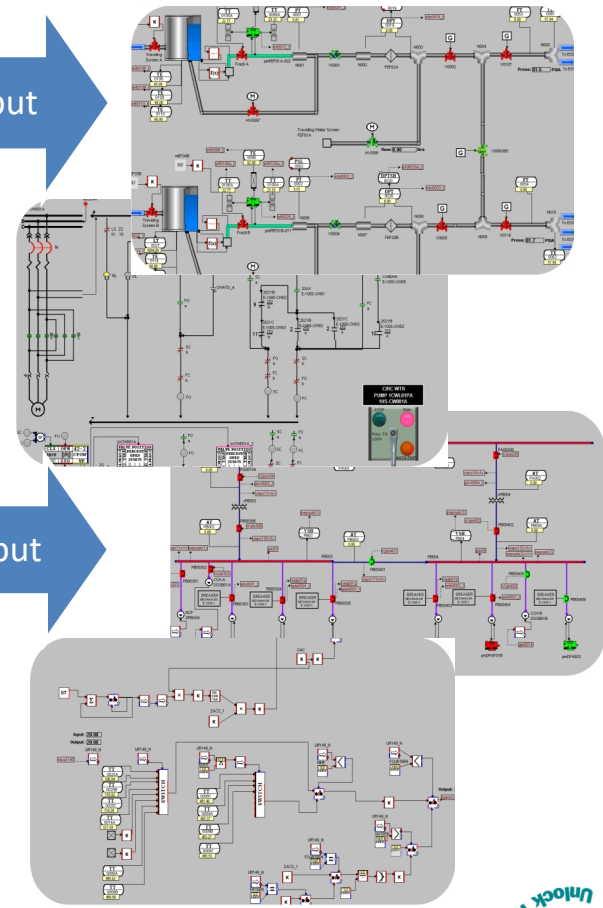
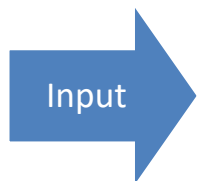



## □ SAE - In New DCS Installations

- ✓ Commissioning time is reduced due the full testing of the Human Machine Interface and Logic & Control on the Simulator
- ✓ Plant procedures are developed and verified on the simulator pre start-up of the unit
- ✓ Reduction of dead or waiting time for commissioning engineers to resolve specific I&C problems
- ✓ Incremental resolution of problems results in reduced commissioning time



- ❑ Major Companies are using simulation in DCS testing
  - ✓ Experience from commissioning of DCS systems is that over 50 % of DCS I&C diagrams are changed during commissioning
  - ✓ Over 70 % of the DCS graphic pages are updated due to mapping, color, & ergonomics errors or improvements
  - ✓ 5-10 % Interface and I/O Errors
- ❑ Simulation can provide a test bed to resolve these errors before commissioning
- ❑ Having an engineering grade full scope simulator allows operation and engineering to use the simulator beyond its primary charter for training

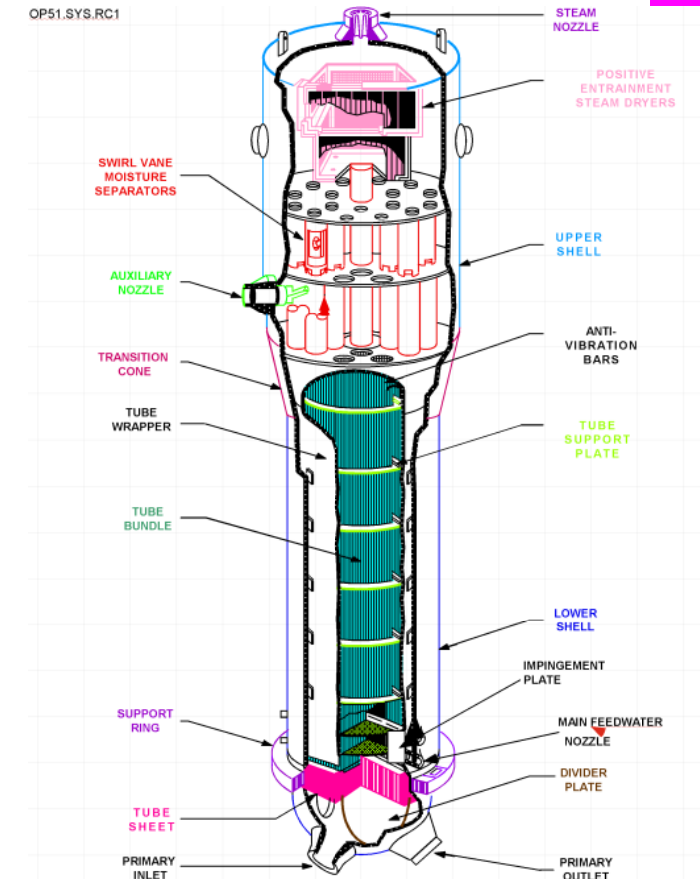

- Typical applications of SAE V&V for logic and controls:
  - Verify logic and controller functional diagrams
  - Address operating in multiple modes simultaneously
  - Ability to change setpoints, bias, or control mode
  - Impact of transmitter failures
  - Ensuring proper IO connections
  - Impact of loss of power supplies on system performance
  - Testing alarm system issues (false actuation or alarms not actuating)
  - Failure Modes and Effects Analysis can be evaluated using malfunction capabilities
  - Resolve inability to reset certain alarms or trips
  - Evaluate automatic actions not operating per design



- Typical applications of SAE V&V for HMI:
  - Identify control buttons not functional, not configured properly, or providing incorrect inputs to logic
  - Verify Input, control, and output interfaces for multiple trains
  - Verify operator selection of manual or automatic controls, trip resets, etc.
  - Evaluate engineering unit conversions or display issues
  - Resolve ergonomics issues requiring renaming of controls or relocation to other screens
  - Optimize popup control priority and precedence
  - Resolve incorrect or false indication of equipment e.g. valve status:
    - scaling issues, such as false contradictory or deceiving indications or bar graphs
    - text flashing or “dynamics” display issues
    - colors or shading
    - other minor issues, e.g. labels, typos, layout, formatting, trend colors





The SAE approach provides an efficient and cost-effective means of detecting and correcting issues prior of a power plant design prior to the actual plant commissioning. The chart below graphically depicts the SAE process and benefits that can be achieved.

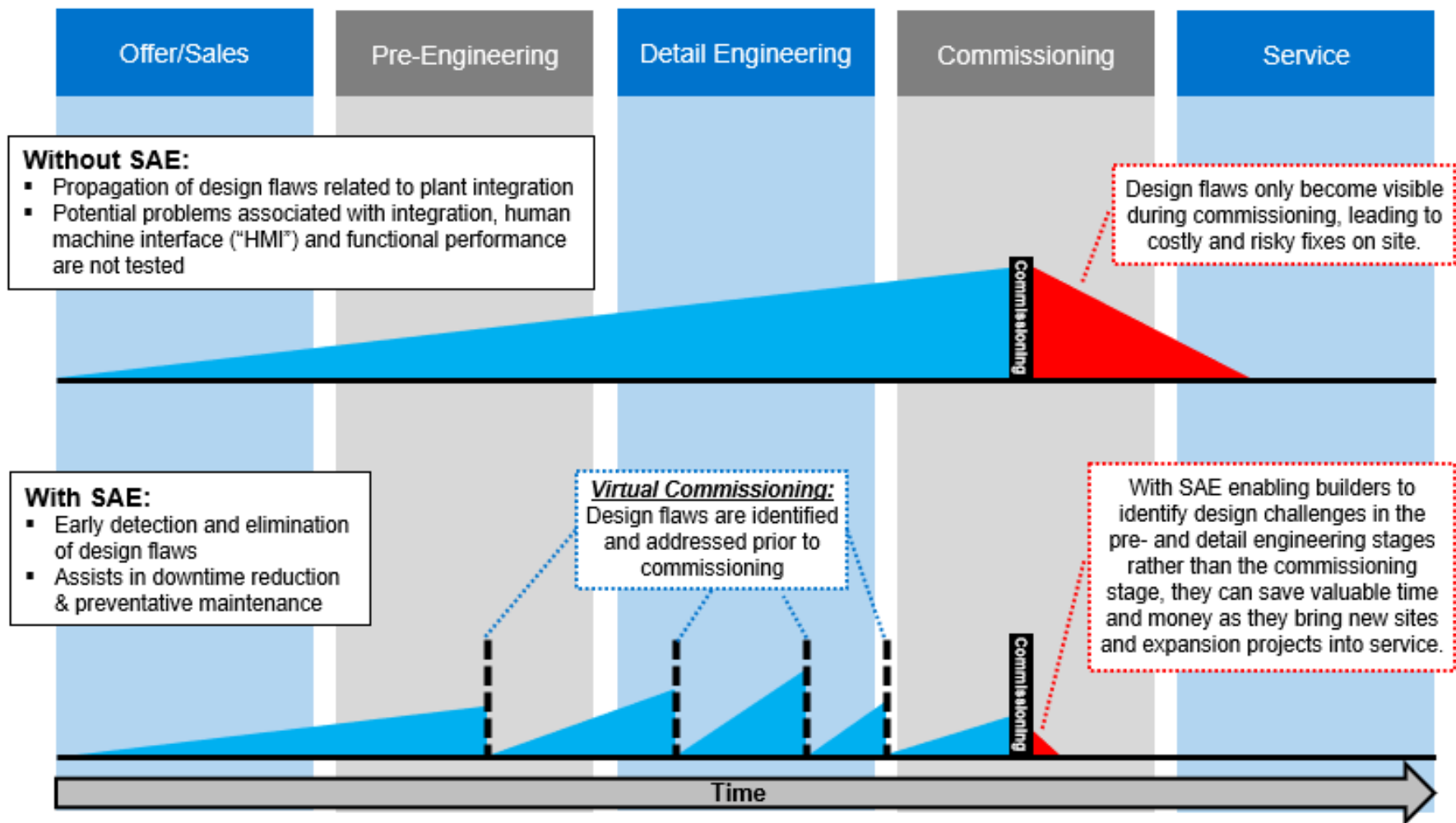

# Benefits and Application of New Design Simulators



## Training

- MCR Operator Training
- Field Operator Training
- Engineers Training
- Plant Management Training

## Engineering Support

- Operating Procedures
- Modifications
- R&D

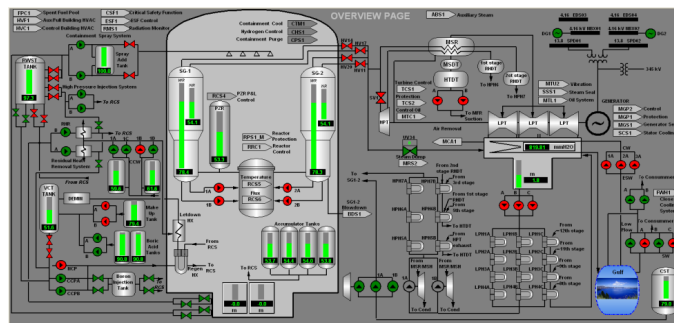

## PR

- Public Visits
- Demonstrations

## Education

- Universities
- TSO
- Regulatory Body



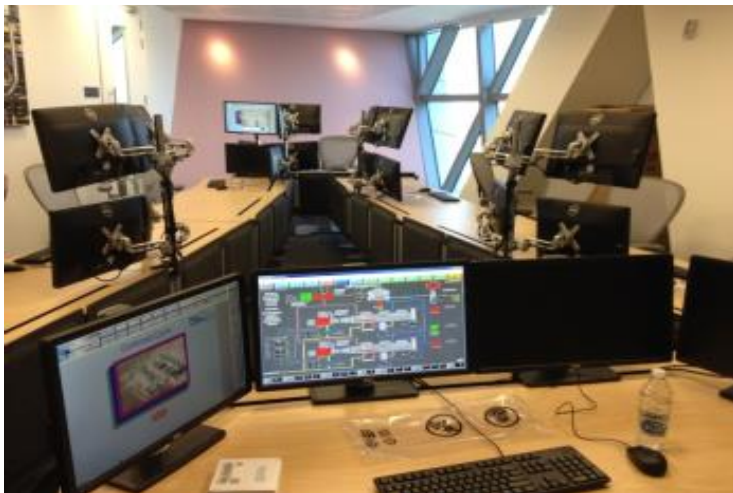

**Thank You!**  
**WSC, Inc.**  
**7196 Crestwood Blvd, Suite 300**  
**Frederick, MD 21703**  
[www.ws-corp.com](http://www.ws-corp.com)

